

# Data Collecting Device

## ProData

### Operating Instructions

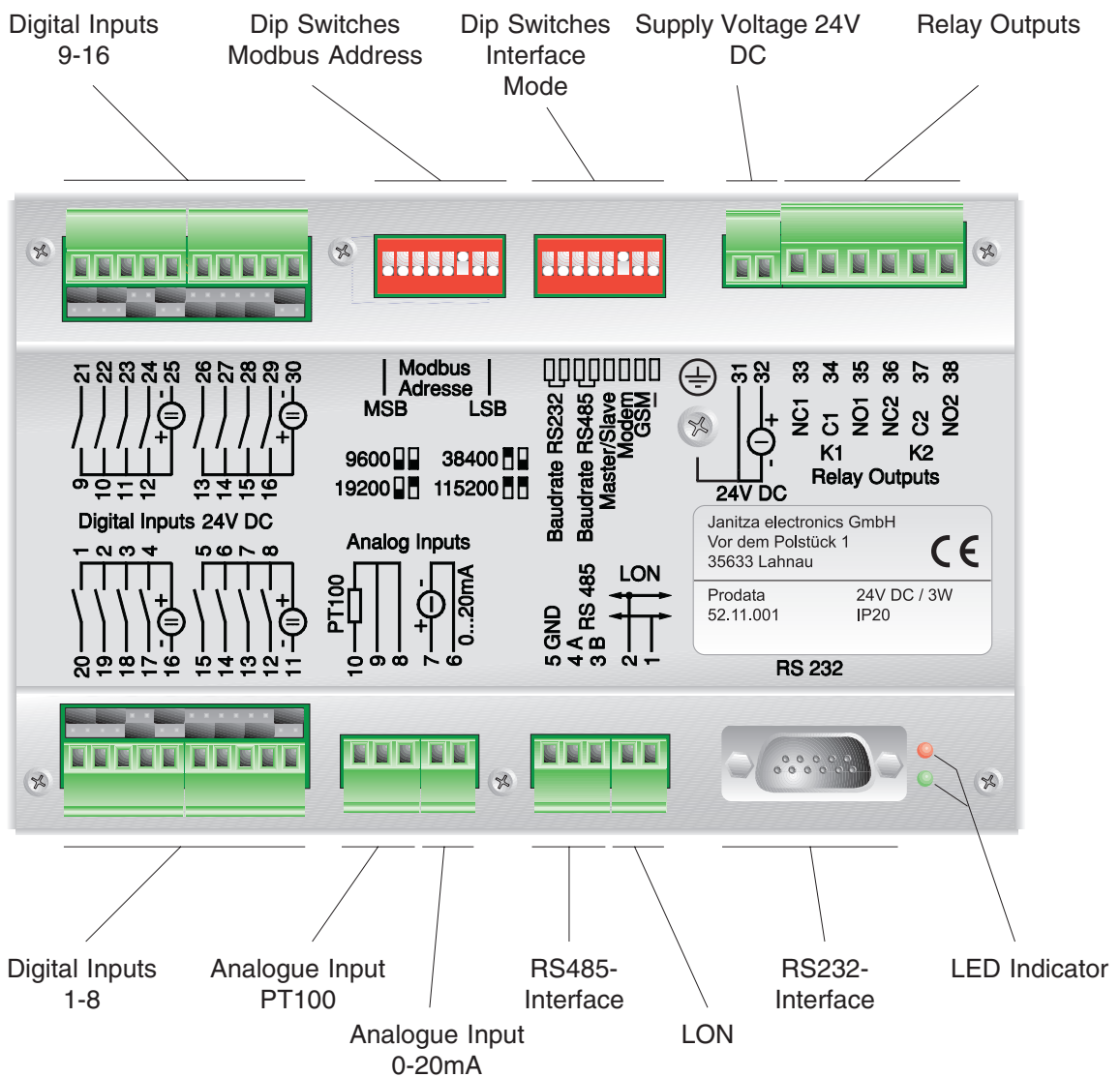

## Table of contents

<b>Generals</b>	<b>3</b>	<b>Dimensions</b>	<b>8</b>
<b>Receipt control</b>	<b>3</b>	<b>Connection Diagram</b>	<b>8</b>
<b>Meaning of the symbols</b>	<b>3</b>	Voltage supply	9
Contents of delivery	3	Setting of the DIP-Switches	9
<b>Hints for maintenance</b>	<b>3</b>	Relay outputs	9
Repair	3	Digital Inputs	10
Cleaning	3	Analogue inputs	11
Battery	3	<b>Serial interfaces</b>	<b>12</b>
Waste management	3	RS485	12
<hr/>		RS232	13
<b>Product description</b>	<b>4</b>	LON-Bus	14
<b>Intended use</b>	<b>4</b>	<hr/>	
<b>Hints for usage</b>	<b>4</b>	<b>Putting into service</b>	<b>15</b>
<b>Functional description</b>	<b>4</b>	<hr/>	
Inputs	4	<b>Technical Data</b>	<b>16</b>
Outputs	4		
Interfaces	4		
Other	4		
Measuring Functions	5		
Data collection	5		
Modbus-Master	6		
Comparators	6		
Modem	7		
GSM-Modem	7		
<hr/>			
<b>Installation Hints</b>	<b>8</b>		

All rights reserved. No part of this manual may be reproduced or duplicated without the written permission of the author. Any contraventions are punishable and will be prosecuted with all legal means.

No liability can be taken for the faultless condition of the manual or damage caused by the use of it. As failures cannot be avoided completely, we shall be very grateful for any advice. We will try to remove any failures as soon as possible. The mentioned software and hardware descriptions are registered trademarks in the most cases and are subjected to the regulations by law. All registered trademarks are property of the corresponding companies and are fully recognized by us.

### Issue note

06.06.2002 First edition.  
24.09.2002 Contents of delivery.  
12.11.2002 Connection diagram.  
11.12.2002 Connection diagram.

# Generals

## Receipt control

In order to ensure a perfect and safe use of the device, a proper transport, expert storage, erection and mounting and careful usage and maintenance are required. When it may be supposed, that a safe operation is no longer possible, the device has to be put out of service and be protected against unintentional putting into service.

A safe operation can no longer be assumed, when the device

- shows visible damage,
- does not work in spite of intact net supply,
- has been exposed to disadvantageous conditions for a longer time (e.g. storage out of the allowed climate without adaption to the room climate, dew etc.) or transport use (e.g. falling from great height, even without visible damage).

Please test the contents of delivery for completion, before starting the installation of the device. All delivered options are listed on the delivery papers.

### Attention!

All plugs, which belong to the contents of delivery, are plugged on the device!

## Meaning of the symbols

The symbols, which are used in this manual, have the following meanings:



Warning of dangerous electrical voltage.



This symbol is supposed to warn you about possible dangers, which can occur during mounting, putting into service and usage.



Protective wire connection

## Hints for maintenance

Before delivery the device is tested in various safety checks and marked with a seal. If the device is opened, these checks must be repeated.

There is no guarantee for devices, which are opened out of the manufacturing works.

### Repair

A repair can be carried out in the manufacturing works only.

### Cleaning

The cleaning of the housing can be done with a soft cloth and common cleaning agents. Acid or acid containing agents may not be used for cleaning the instrument.

### Battery

The life expectance of the battery is 5 years minimum for a storage temperature of +45°C. The typical life expectance of the battery is about 8 to 10 years. The battery is plumbed and should be exchanged in the manufacturing works only.

### Waste management

The ProData can be disposed as electronical waste according to the legal regulations and recycled. Please note, that the input Lithium battery must be disposed separately.

## Contents of delivery

Description	Part Number
Data collecting device, ProData	5211001
Zero modem cable	0802405
Operating instructions, English	3303043
CD, Programming instructions ProData (PDF), Programming software PSW505	3201009

# Product description

## Intended use

ProData is suited for fix DIN rail mounting in low voltage switchboard for determination and storage of metering pulses and process data. These data can be used for the evaluation of energy consumption, working hours or supervision of switching conditions or disturbances in buildings or factories. The alarm at disturbance or violation of thresholds etc. can be effected by relay outputs, analogue modem or GSM modem. The connection of the supply voltage, digital inputs and the interfaces is carried out via touch proof plugs or D-Sub plugs. For the operation of ProData, a protective wire is necessary.

## Hints for usage

This device may be put into service and used by qualified personnel according to the safety regulations and instructions only. Please mind the additional legal and safety regulations for the respective application.

Qualified personnel are persons, familiar with erection, mounting, putting into service and usage of the product and having the qualifications such as:

- education or instruction / entitlement to switch, release, ground or characterize current circuits and devices according to the standards of safety techniques.
- education or instruction in the care and usage of suitable safety equipment according to the standards of safety techniques.

## Functional description

The supply voltage is connected via an external 24VDC net supply, the allowed voltage input at ProData is 8V...28V.

To carry out an update of the firmware, the voltage must be at least 15V. The voltage input is protected against change of polarity.

## Inputs

- 16 digital inputs, which can be configured as record relay input or pulse input with plug terminals of class A according to EN62053-31:1998.
- 1 input for process signals 0...20mA or 4...20mA, potential free, isolated up to 32V against housing.
- 1 terminal for an external temperature sensor, Pt100, Pt200, Pt500 or Pt1000 sensors with two wire or three wire connection can be used. Alternatively, a KTY83-110 or -120 can be used.

## Outputs

- 2 relays with change over contact

## Interfaces

- RS232 interface, baud rate settable for 9600, 19200, 38400 or 115200 Baud, protocol Modbus/RTU, only slave mode. At RS232 interface, a modem can be connected.
- RS485 interface, baud rate settable for 9600, 19200, 38400 or 115200 Baud, protocol Modbus/RTU, Slave or Master operation possible. Potential free, isolated up to 32V against housing.
- LON with FTT-10A Transceiver.

## Other

- Dip switches for setting the baud rates, modbus addresses and master operation.
- 2 LEDs (red and green), freely programmable.
- Real time clock with automatic summer/winter change over.
- Lithium battery (about 10 years life expectance) for clock and memory contents.

## Measuring Functions

### Digital inputs

- Total pulse counter at each input, maximum counter frequency 50Hz, maximum meter count  $2^{64} - 1$ , the meter count is increased by 1 with each positive edge.
- Pulse counter with external reset or reset in programmable time intervals from 1 sec. to 12h, with automatically saved counter of the last reset.
- Detection of the total on and off time for each input. Solution 1sec, maximum time  $2^{32} - 1$ sec.
- Detection of circuit-closing in programmable time intervals (1sec...12h), automatical storage of the last value.
- Detection of the on and off time since the last change of condition of an input (max  $2^{32} - 1$ sec).
- Frequency measurement at each input, gate time  $\geq 10$ sec, maximum frequency 50Hz, free selectable scales for calculation of the measured frequency into physical quantities (Power, pressure etc.).

The measured values can be read out via Modbus. Via LON, the counters are available as 32-Bit values (overflow of the counter after  $2^{32}$  pulses).

### Analogue Inputs

- Measurement of currents in the range of 20mA, input in the range of -20mA...20mA. Within this range, a full scale and an offset can be set (Example 4...20mA).  
The measured current is calculated in a value of 0...1 according to these values.
- Measurement of an external temperature with sensors Pt100, Pt200, Pt500 or Pt1000. Linearization in the range of -150°C...400°C, solution 0,1°C, inaccuracy 1°C, linearization error in this range 0,5°C.
- Alternatively to the Pt100 sensor, a Silicium temperature sensor of the type KTY83-110 or KTY83-120 (-50°C...170°C) can be used
- Measurement of the internal temperature (within the housing) in the range of -20°C...80°C, solution 1°C, inaccuracy 5°C.

The measured values can be read out via Modbus. For LON, both temperature values and the scaled 20mA measured value are available.

## Data collection

The analogue values and additionally 7 further measured values can be saved in selectable time intervals (1sec...12h) as mean, minimum and maximum values.

In programmable time intervals (1sec...12h) or synchronized externally, the difference of the total counters to the actual counters of the last time of storage is calculated and saved. The maximum counter for this difference is 60000, if this is exceeded, the immediate saving of the difference counter of the corresponding input is effected.

Changes of conditions can be saved with date and time (1sec solutions) for all input.

Various internal events (for example breakdown and return of voltage supply) can be saved.

Changes of the programmable comparator can be saved as events with date and time.

All saved values and events are saved in a ring buffer. This has about 440kB, the size of a saved event varies between 8 Byte (single event) and 40 Byte (difference counter of 16 channels) up to 2046 Bytes (Upper limit of data format). When all 16 counters should be saved, the memory is sufficient for about 3 months.

The filling of the ring buffer and the number of free Bytes can be read out via Modbus. The reading and deletion of the ring buffer is also done via Modbus, where special addresses are used, that effect complex operations within the device (Reading or deletion of an element from ring buffer).

## Modbus-Master

The RS485 interface can be used in Modbus master mode. In this mode, ProData can read registers of other Modbus devices (for example further ProData or UMG503). ProData can write the results of the programmable comparators into registers of other devices as well. For example, the number of relay outputs can be expanded by connecting a Modbus module as slave.

The following data types can be read out:

- Integer values 16-Bit with sign
- Integer values 16-Bit without sign
- Integer values 32-Bit with sign (with reverse sequence MSB/LSB)
- Integer values 32-Bit without sign (with reverse sequence MSB/LSB)
- 32-Bit-values in IEEE floating point format (float), MSB/LSB reversible
- Integer values 48-Bit with sign (with reverse sequence MSB/LSB)
- Integer values 48-Bit without sign (with reverse sequence MSB/LSB)
- Integer values 64-Bit with sign (with reverse sequence MSB/LSB)
- Integer values 64-Bit without sign (with reverse sequence MSB/LSB)

The following data types can be written:

- boolean values (0 or 1) as 16-Bit-values (simple writing access to a 16-Bit register).
- boolean values as single Bit of a 16-Bit registers, Bit position programmable (The register is read, the Bit is manipulated and written into the register again)

In Modbus master mode, all Modbus telegrammes, which appear at the RS232 interface, but are not valid for ProData, are transmitted to the connected slaves at RS485-Bus. The response telegrammes of the slaves are transmitted to the RS232 interface. This function is available for the Modbus functions 03 (Read Holding Registers), 06 (Preset Single Register) and 16 (Preset Multiple Registers). Other functions are not transmitted.

## Comparators

The Prodata has 128 programmable comparators. Those compare an input value with an upper and lower limit (with hysteresis), if the value is within or outside of the window, defined by the two limits. The result can be linked with the result of another comparator by a logical combination (AND, OR, NOT). Depending on this result, various action can be carried out. Switch on and switch off delay can be programmed separately.

Each available measured value or register content can be used as input value for a comparator. In Modbus-Master-mode also a measured value or register of a slave device can be used as input value.

The following actions are possible:

- Switch on or off relay output or LED.
- Switch on relay output or LED for a programmable time.
- Set internal condition flag.
- Save event in ring buffer.
- Write the result of a comparator into a register of a Modbus slave.
- For modem operation, a server can be called to effect a message.

The internal condition flags (4 pieces) can be read out via LON as well, the relays and LEDs can be switched via LON.

## **Modem**

A modem can be connected to the RS232 interface. Input calls are received and the protocol Modbus is activated via modem.

All data can be read out, and the device can be programmed.

Depending on the result of a comparator, the device can establish communication to a server by itself and send a message. This presupposes a program on the server, which can communicate with ProData. On a Linux-Server, the program mgetty in combination with mail command is suitable.

## **GSM-Modem**

Instead of an analogue modem, a GSM modem can be connected.

With a GSM modem, there is an additional possibility of sending an SMS while some limits (comparator results) are exceeded. Via incoming SMS, internal registers can be set, and actions can be effected by a comparator.

At present, this function has been tested and specified exclusively with the GSM-Modem GS-01 of Westermo ([www.westermo.se](http://www.westermo.se)). The use of other GSM modems is the own responsibility of the end user.

# Installation Hints

## Dimensions

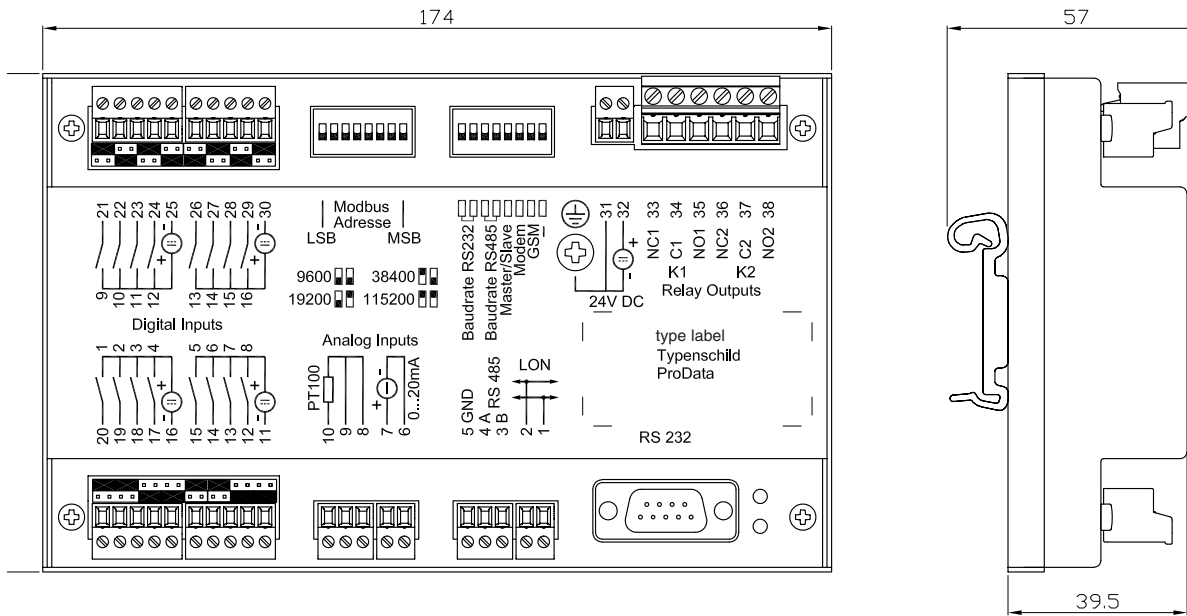

## Connection Diagram

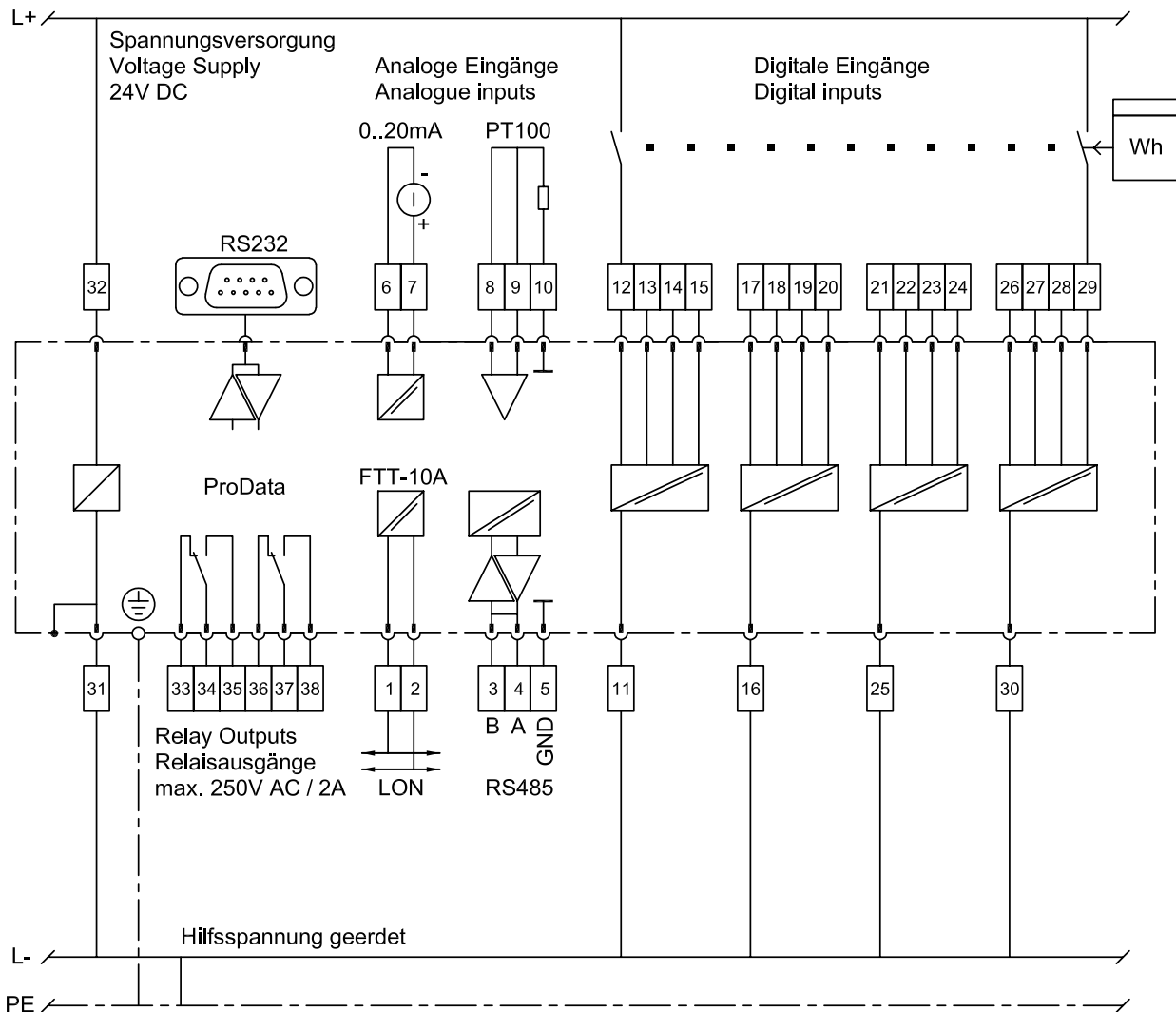

## Voltage supply

To the terminals 31(-) and 32(+) an external voltage supply is connected to ProData.

The rated voltage is 24V DC (+15/-35%) and power consumption of about 3W.



The external voltage supply must be isolated twice against life voltage, which means a testing voltage of at least 2300VAC between primary and secondary circuit (DIN EN 61010). The ProData is a device of protection class I and may be operated with protective ground connection only. The minus pole of the supply voltage must be earthed.

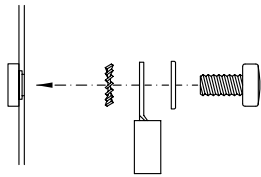

Diagr.. Protective wire connection

## Setting of the DIP-Switches

### Modbus-Address

If more devices are connected to each other via the RS485 interface, a master device (PC or PLC) can separate them by means of their device address. Within a network, each ProData must have its own device address. The address can be set in the range of (0) 1 up to 247 as a binary number.

Example for device address 19:

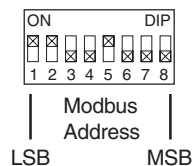

## Relay outputs

At the terminals 33...38 two potential free contacts, K1 and K2 are available. The relays can switch up to 250V AC and a current of 2A.

## Interface operation mode

With the second DIP switch, the setting of the baud rate for the interface RS232 and RS485 as well as the operation mode master or slave for RS485 and the selection of the modem for RS232 connection can be set.

Example 1:  
 Baud rate RS232: 9600  
 Baud rate RS485: 19200  
 Master Slave: Slave  
 Modem: None  
 GSM: -----

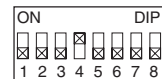

Example 2:  
 Baud rate RS232: 19200  
 Baud rate RS485: 38400  
 Master/Slave: Master  
 Modem: Yes  
 GSM: No

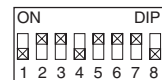

Example 3:  
 Baud rate RS232: 38400  
 Baud rate RS485: 115200  
 Master/Slave: Slave  
 Modem: Yes  
 GSM: Yes



Example 4:  
 Baud rate RS232: 115200  
 Baud rate/RS485: 9600  
 Master Slave: Master  
 Modem: No  
 GSM: -----

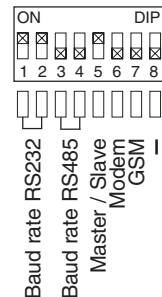

## Digital Inputs

To the terminals 11...30 of ProData, 16 digital input signals can be attached. They can be separated into alarm and pulse inputs.

Alarm inputs are used for mechanical switches or semiconductor switches, which do not consume energy from the switching signal.

Pulse inputs are used for external fed two wire pulse applications, which consume the energy, which is necessary for their function from the switching signal, which results in a rest current.

The pulse inputs of ProData are designed for pulse applications of class A according to EN62053-31:1998.

The digital inputs of ProData must be programmed correspondingly via code bridges.

In this example, the inputs 3 and 4, 7 and 8, 9, 11, 14 and 16 are programmed as pulse inputs. The other inputs are alarm inputs.

For the operation of the inputs, an external supply voltage of 24VDC is required.

The inputs are potential free and isolated up to 32V against ground.

4 inputs are collected in one group.

Connection example:

Digital input 8 is a pulse input, digital inputs 5, 6 and 7 are alarm inputs.

External supply voltage 24V DC.

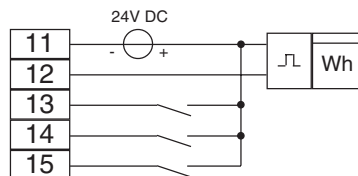
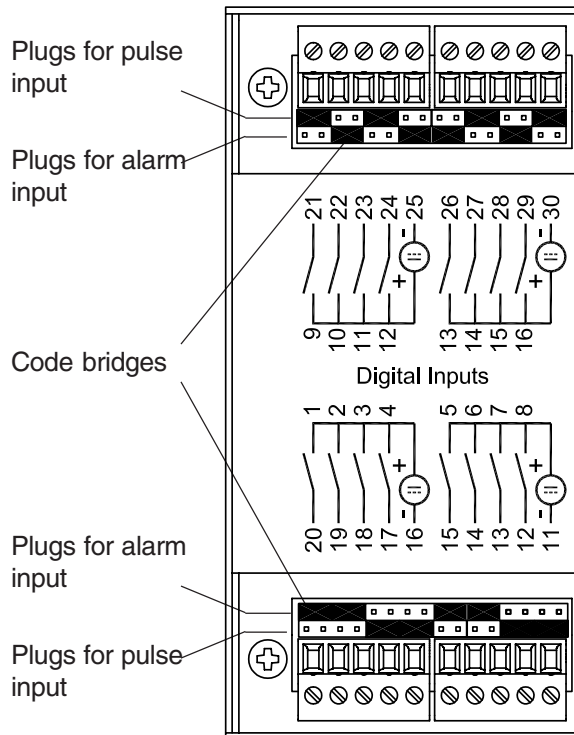

## Analogue inputs

### Temperature measurement

At clamps 8...10 of ProData, it is possible to connect temperature sensors of the type PT100...PT1000 or KTY83-110 and KTY83-120. For 3-wire-connection, the resistance of the cable is compensated.

3-wire-connection  
PT100

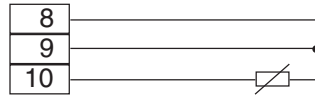

2-wire connection  
PT100. Clamp 8 and  
9 are bridged.

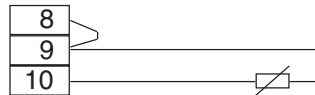

2-wire-connection  
KTY83-110. Clamp 8  
and 9 are bridged.

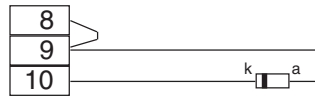

Connecting the semiconductor temperature sensor KTY83-110 / -120, please mind, that the negative connection, marked by a black ring, is connected to clamp 10.

### Process signal 0...20mA

The clamps 6 and 7 of ProData provide an input for measuring a process signal in the range of -20mA...0...+20mA. The input is potential free and isolated against ground up to a voltage of 32V, the load is 10 Ohm. Clamp 7 is the positive connection.

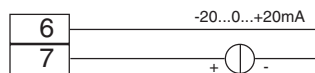

# Serial interfaces

## RS485

### Terminal resistors

All devices are connected in bus structure (line). In one segment, up to 32 participants can be connected to each other. At the beginning and the end of a segment, the cable is terminated by a resistor, which corresponds to the resistance of the wire (120 Ohm). In ProData, the termination resistor can be connected to the terminals.

For more than 32 participants, repeaters have to be used (amplifiers), to connect the single segments.

### Shielding

For communication via RS485 interface, a twisted pair and shielded cable has to be used. To achieve the required shielding result, the shielding must be connected at both ends of the cable well conducting with housing or panel parts.

### Cable type



Example Unitronic LI2YCYCTPJ2x2x0,22 (Lapp Cable)

### Cable length

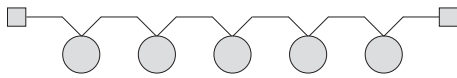
1000m at Baud rate of 38,4k.



Diagr. Bus structure with termination resistors at both sides.

-  Terminal resistor
-  Device with RS485 interface

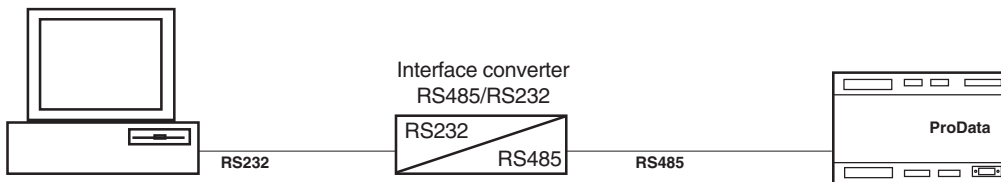

## RS232

The achievable distance between two RS232 devices depends on the used cable and the baud rate. As an estimation may serve, that the distance for a baud rate of 9600 Baud should not exceed 15...30 meters. The allowed load must be more than 3kOhm, the capacitive load caused by the transmission power is limited to 2500 pF.



*Diagr. Connection of two devices with RS232 interface*

### Connection of the DSUB-plug

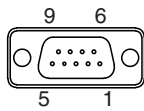

- |               |         |
|---------------|---------|
| 1 - DCD       | 6 - DSR |
| 2 - RXD       | 7 - RTS |
| 3 - TXD       | 8 - CTS |
| 4 - DTR       | 9 -     |
| 5 - GND       |         |
| Housing - GND |         |

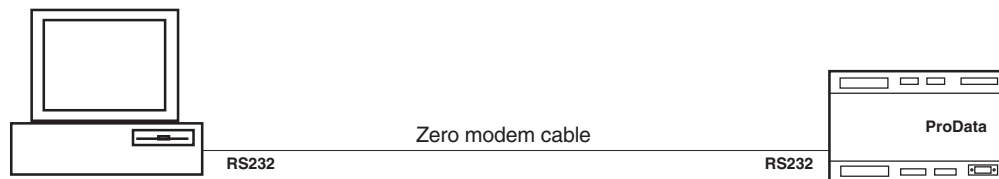
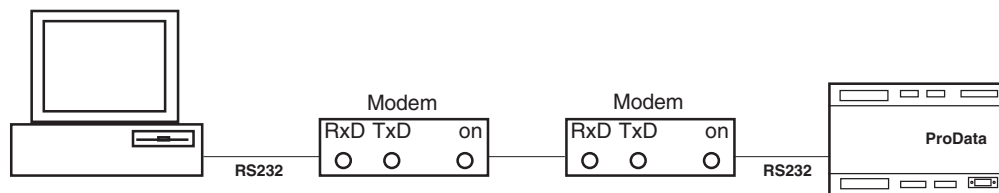

## LON-Bus

For the connection of ProData to other LON-bus devices, a FTT10-Transceiver is inserted in the ProData. The bus is protected against change of polarity and can be connected on one or two sides. Devices, which use a FTT10 -Transceiver, can be linked in line, star or ring structure.

If the allowed transmission resistance in a structure is reached, the network can be expanded by using repeaters or routers.

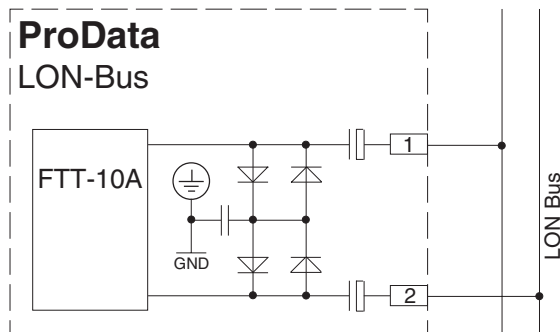

Diagr.: Connection to LON-bus

### Bus wiring

When the device is wired in bus structure on both sides, the maximum total cable length may not exceed 2700m. ProData does not contain a termination resistor for LON-bus.

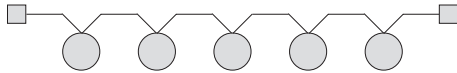

Diagr.: Bus structure with termination resistors on both sides.

### Free wiring

For free wiring and bus connection on one side, the maximum total cable length may be 500m and the maximum distance between two devices may be 400m.

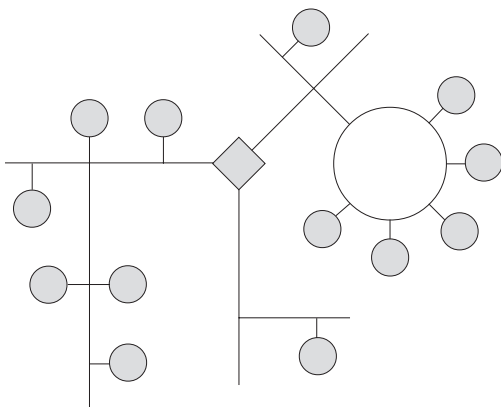

Diagr.: Free structure

### Allowed cable length

Depending on the selected structure of the network and the used cable type, some different transmission distances can be reached

Cable Type	Distance	
	Total	Device - Device
TIA 568A Category 5	500m	< 250m
Belden 85102, 16AWG	500m	< 500m
Belden 8471	500m	< 400m
UL Level IV, 22AWG	500m	< 400m
JY(St)Y 2x2x0.8, 20AWG	500m	< 320m

Diagr.: Maximum cable length for **free wiring**.

Cable type	Distance
TIA 568A Category 5	< 900m
Belden 85102, 16AWG	< 2700m
Belden 8471	< 2700m
Level IV, 22AWG	< 1400m
JY (St) Y 2x2x0.8, 20AWG	< 900m

Diagr.: Maximum cable length for **bus wiring**.

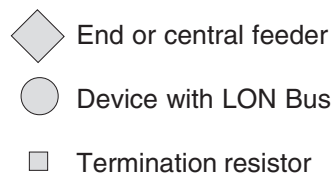

## Putting into service

The device should be put into service after installation as follows:

### 1. Configure the device

- The code bridges of the digital inputs must be plugged according the required use of the input, which means as alarm input or pulse input.
- The Modbus address must be set at the corresponding DIP switch.
- The operation mode of the interfaces must be set at the corresponding DIP switch.

### 2. Connect power supply

ProData requires an earthed power supply of 24V DC.

### 3. Set parameters

Please set the parameters of ProData by means of a PC via RS232 interface or RS485 interface.

- Connect ProData via an interface to a PC and set the parameters with software PSW basic/professional.

## Technical Data

Ambient conditions	
Overvoltage class	: CATII
Pollution degree	: 2
Operation temperature	: -10°C .. +55°C
Storage temperature	: -20°C .. +60°C
Relative humidity	: 15% .. 95% without dew
Operation height	: 0 .. 2000m over NN
Protection class	: IP20 according to IEC529
Testing voltage	: 3250V DC
Voltage supply Uh	: 24V DC (+15/-35%)
Power consumption	: max. 3 VA
Relay outputs	: 2 changers ( 230V AC / 2A)
Analogue inputs	
Temperature measurement	: PT100, PT200, PT500, PT1000 KTY83-110, KTY83-120
Process signal 0...20mA	: -20...0...+20mA
Inaccuracy	: +/- 0,3mA
Digital inputs	: pulse input for pulse senders of class A according to EN62053-31:1998 or alarm input
Interfaces:	
RS232	: Baud rate 9600, 19200, 38400 or 115200
RS485	: Baud rate 9600, 19200, 38400 or 115200
Accuracy of internal clock	: +/- 1 Minute/Month
Mounting position	: Any